

SECTION A-A

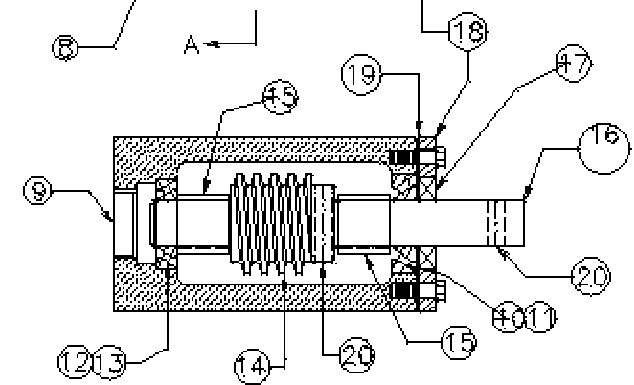

SECTION B-B

BILL OF MATERIAL			
ITEM	PART #	QTY.	DESCRIPTION
--	700-00105	1	TURN DEVICE GEAR BOX ASS'Y W/ LONG SHAFT
1	700-00106	1	TURN DEVICE HOUSING COVER
2	700-00107	1	TURN DEVICE COVER GASKET
3	700-00108	1	TURN DEVICE TOP SEAL
4	700-00109	2	TURN DEVICE BEARING CUP
5	700-00110	2	TURN DEVICE BEARING CONE
6	700-00124	1	TURN DEVICE MAIN GEAR
7	700-00133	1	T.D. TOP BEARING SUPPORT SHAFT
8	700-00112	1	TURN DEVICE HOUSING
9	700-00113	1	TURN DEVICE EXPANSION PLUG
10	700-00114	1	TURN DEVICE BEARING CUP
11	700-00115	1	TURN DEVICE BEARING CONE
12	700-00116	1	TURN DEVICE BEARING CUP
13	700-00117	1	TURN DEVICE BEARING CONE
14	700-00125	1	TURN DEVICE WORM GEAR
15	700-00118	2	TURN DEVICE SPACERS
16	700-00119	1	TURN DEVICE HORIZONTAL SHAFT
17	700-00120	1	TURN DEVICE SEAL
18	700-00121	1	TURN DEVICE END COVER
19	700-00122	1	TURN DEVICE END COVER GASKET
20	200-00013	2	ROLL PIN

UNLESS OTHERWISE SPECIFIED:  
DIMENSIONS ARE IN INCHES  
DECIMALS    ANGULAR    FRACTIONS  
XXX ± .01    ± °    ± 1/64"  
XXX ± .006  
DO NOT SCALE DRAWING



WARREN MFG.

DESIGN	DATE	DRAWING NAME		
SRG	10/09	TURN DEVICE ASS'Y		
CHECKED		SIZE	PSGN. NO.	DWG. NO.
		D		
		SCALE	NTS	SHEET 1 of 1